

3.1 HW19710变速器总成/HW19710 Transmission Assembly

序号/ No.	名 称 / Designation	页 码 /Page No.
3.1.01	变速箱总成/Transmission Ass.	1
3.1.02	变速器前壳组件/Transmission Front Housing	2
3.1.03	变速器中壳组件/Transmission Housing -Middle	3
3.1.04	输入轴及端盖组件(细高齿)/Input Shaft and Cover	4
3.1.05	副轴组件/Auxiliary Shaft	6
3.1.06	主轴组件/Main Shaft	7
3.1.07	惰轮轴组件/Idle Wheel	8
3.1.08	范围档副箱组件/Sub Gearbox	9
3.1.09	小盖组件/Small Cover	15
3.1.10	拨叉轴组件/Fork Shaft	18
3.1.11	油泵及管路组件/Pump and Pipe	19
3.1.12	气动管路阀组件/Air Pipe and Valve	21
3.1.13	离合器操纵组件	22
3.1.14	变速器操纵附件/Shifting Accessories	23
3.1.15	电器开关组件(电磁式传感器)/Electric Switch	24
3.1.16	标牌组件/Nameplate	25
3.1.17	取力器组件/PTO	26

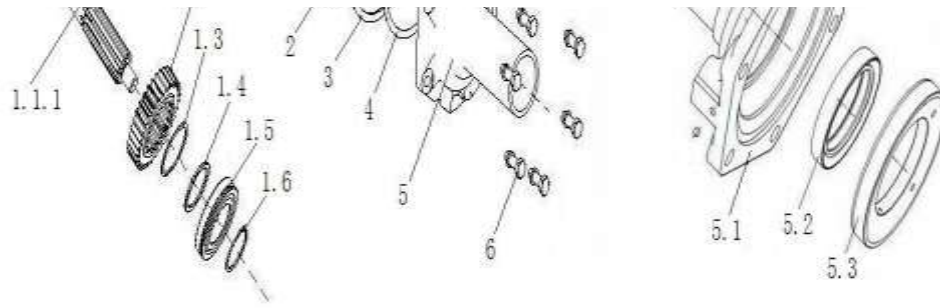

3.1.04 输入轴及端盖组件(细高齿)/Input Shaft And Cover

序号	零部件图号	名称	Part Name	数量	备注
No.	Part No.			Qty	Remark
1	AZ2203020021	输入轴及一轴齿轮总成	Input shaft & gear assembly	1	
1.1	AZ2203020103	输入轴总成	Input shaft assembly	1	
1.1.1	WG2210020105	输入轴	Input shaft	1	
1.1.2	WG2229020005	衬套	Bushing	1	
1.2	WG2210020322	一轴齿轮	Gear	1	
1.3	WG2229040003	卡簧	Clip	1	
1.4	WG2229040103	隔套	Sleeve	1	
1.5	WG9003326213	滚动轴承6213N-GB/T276	Bearing	1	
1.6	AZ2208020001	卡簧选用件组	Clip components	1	
1.6.1	WG9003991065	轴用弹性挡圈	Circlip	1	
1.6.2	WG9003992065	轴用弹性挡圈	Circlip	1	
1.6.3	WG9003993065	轴用弹性挡圈	Circlip	1	
1.6.4	WG9003994065	轴用弹性挡圈	Circlip	1	
1.6.5	WG9003995065	轴用弹性挡圈	Circlip	1	
2	WG2229020015	输入轴端盖纸垫	Gasket	1	
3	WG9003990120	止动环120/129.7-GB305	Ring	1	
4	AZ2208020002	输入轴承调整垫片组	Shim	1	
4.1	WG2229020011	调整垫片	Shim	1	
4.2	WG2229020012	调整垫片	Shim	1	
4.3	WG2229020013	调整垫片	Shim	1	

3.1.04 输入轴及端盖组件(细高齿)/Input Shaft and Cover

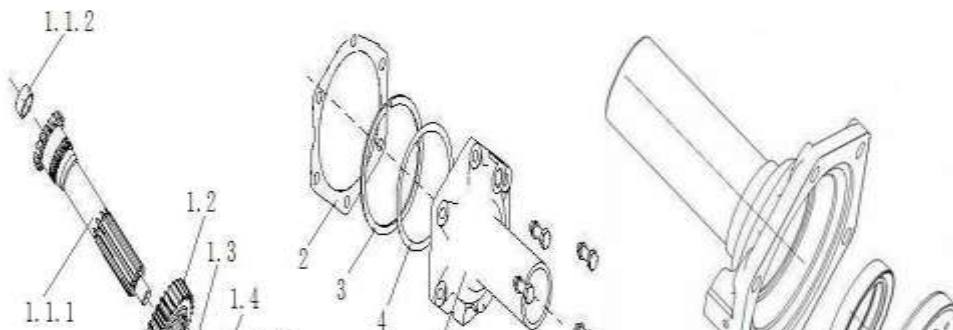

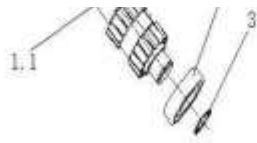

3.1.05 副轴组件(细高齿)/Lay Shaft

序号 No.	零部件图号 Part No.	名称	Part Name	数量 Qty	备注 Remark
1	AZ2203030211	副轴总成(左)	Countershaft assembly L	1	
1,1	AZ2210030335	副轴 (左)	Countershaft L	1	
1,2	WG9003329309	圆柱滚子轴承NUP309E (左)	Cylindrical roller bearing	1	
1,3	Q43160	轴用弹性挡圈	Circlip	1	
1,4	WG2210030325	副轴传动齿轮	Gear	1	
1,5	WG2210030326	副轴四挡齿轮	Gear	1	
1,6	WG2210030324	副轴三挡齿轮	Gear	1	
1,7	WG2210030203	副轴二挡齿轮	Gear	1	
1,8	WG2229030003	长平键	Key	1	
2	AZ9003990100	止动环100/106.5-GB305	Ring	2	
3	Q43145	轴用弹性挡圈	Circlip	4	
4	WG9003320309	圆柱滚子轴承NUP309E (右)	Cylindrical roller bearing	2	
5	AZ2203030212	副轴总成(右)	Countershaft assembly R	1	
5,1	AZ2210030340	副轴 (右)	Countershaft R	1	
5,2	WG9003329309	圆柱滚子轴承NUP309E (右)	Cylindrical roller bearing	1	
5,3	Q43160	轴用弹性挡圈	Circlip	1	
5,4	WG2210030325	副轴传动齿轮	Gear	1	
5,5	WG2210030326	副轴四挡齿轮	Gear	1	
5,6	WG2210030324	副轴三挡齿轮	Gear	1	
5,7	WG2210030203	副轴二挡齿轮	Gear	1	
5,8	WG2229030003	长平键	Key	1	

3.1.06 主轴组件(细高齿)/Main Shaft

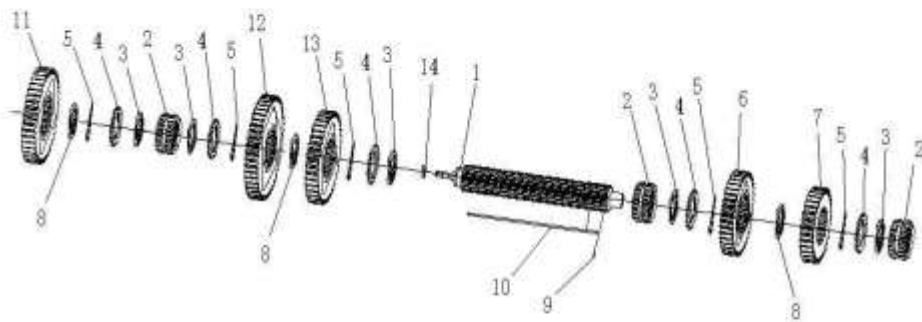

3.1.06 主轴组件(细高齿)/Main Shaft

序号 No.	零部件图号 Part No.	名称	Part Name	数量 Qty	备注 Remark
1	WG2203040030	主轴带球头总成	Main shaft assembly	1	
2	WG2210040210	主轴滑套	Sleeve	3	
3	WG2229040073	主轴齿轮挡片	Shim	5	
4	WG2210040608	花键挡片	Shim	5	
5	WG2229040420	孔用压扁钢丝挡圈	Circlip	5	
6	WG2210040425	主轴三挡齿轮	Main shaft 3rd gear	1	
7	WG2210040424	主轴四挡齿轮	Main shaft 4th gear	1	
8	WG2229040072	主轴齿轮隔片	Shim	3	
9	Q5280514	弹性圆柱销	Pin	2	
10	WG2229040223	六角键	Key	1	
11	WG2210040319	主轴倒挡齿轮	Gear	1	
12	WG2210040440	主轴一档齿轮	Main shaft 1st gear	1	
13	WG2210040416	主轴二挡齿轮	Gear	1	
14	AZ2208040002	主轴大挡片	Shim	1	

3.1.07 惰轮轴组件/Idle Wheel

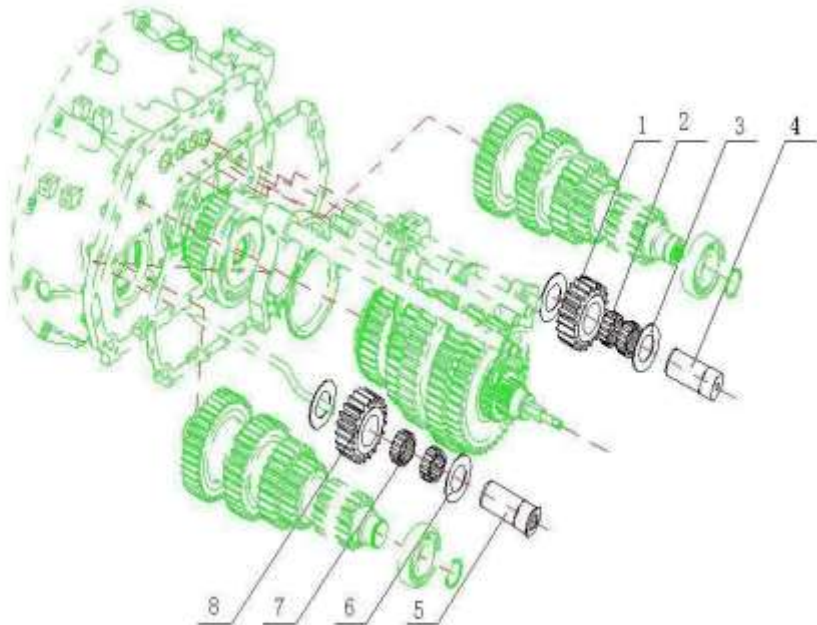

No.	Part No.	名称	Part Name	Qty	Remark
1	AZ2220100105	变速器后壳	Rear housing	1	
2	WG9003326020	滚动轴承6020 GB/T276	Roller bearing	1	
3	Q5280630	弹性圆柱销	Pin	5	
4	Q5280430	弹性圆柱销	Pin	5	
5	AZ2203100002	行星架总成	Planetary gear frame assembly	1	
5,1	WG9003821255	内六角圆柱头螺钉M12X1	Screw	5	
5,2	WG2225100002	行星架（前）	Planetary gear frame	1	
5,3	WG2229100001	传扭套	Sleeve	5	
5,4	AZ2225100001	输出轴	Output shaft	1	
5,5	AZ9007970271	螺纹紧固胶LOCTITE271	Thread glue	1	
6	WG2229100005	太阳轮垫片(前)	Gasket	1	
7	AZ2203100003	太阳轮及套总成	Gear assembly	1	
7,1	WG2210100002	花键套	Sleeve	1	
7,2	Q43875	孔用钢丝挡圈	Circlip	1	
7,3	WG2210100003	过渡套	Sleeve	1	
7,4	WG2210100001	太阳轮	Gear	1	
8	WG2229100006	太阳轮垫片(后)	Gasket	1	
9	WG9003326322	滚动轴承63/22 GB/T276	Roller bearing	1	
10	WG2212100001	行星轮轴	Shaft	5	
11	WG2229100007	滚子间隔片	Shim	15	

3.1.08 范围挡副箱组件（取力器、电磁式传感器）/Sub Gearbox

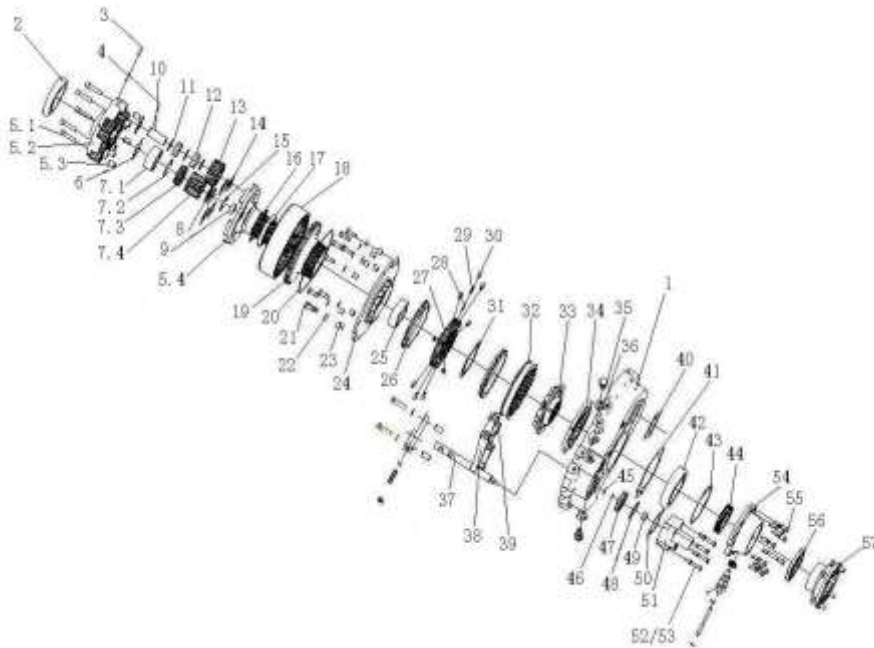

3.1.08 范围挡副箱组件（取力器、电磁式传感器）/Sub Gearbox

序号	零部件图号	名称	Part Name	数量	备注
No.	Part No.			Qty	Remark
12	WG9003321118	圆柱滚子11X18IIIb GB4661	Roller	120	
13	WG2210100004	行星轮	Gear	5	

14	WG2229100008	行星轮垫片	Shim	10	
15	WG9003991056	孔用弹性挡圈	Circlip	1	
16	WG9003991125	孔用压扁钢丝挡圈	Circlip	1	
17	WG9003321820	滚动轴承61820 GB/T276	Bearing	1	
18	WG2210100005	内齿圈	Ring gear	1	
19	WG2210100006	齿圈支架	Bracket	1	
20	WG2229100012	钢丝挡圈	Circlip	1	
21	Q150B1240	六角头螺栓	Bolt	9	
22	Q40112	平垫圈	Washer	9	
23	WG2229100002	传扭套	Sleeve	9	
24	WG2203100005	低档锥毂总成	Tapered plate assembly	1	
25	WG2229100032	隔套	Sleeve	1	
26	WG2210100109	范围档同步环	Ring	2	
27	WG2210100007	范围档同步齿座	Base	1	
28	WG2229020003	推块内弹簧	Spring	9	
29	WG2229020002	推块外弹簧	Spring	9	
30	WG2229020001	同步推块	Block	9	
31	WG9003991130	轴用弹性挡圈	Circlip	1	

3.1.08 范围档副箱组件（取力器、电磁式传感器）/Sub Gearbox

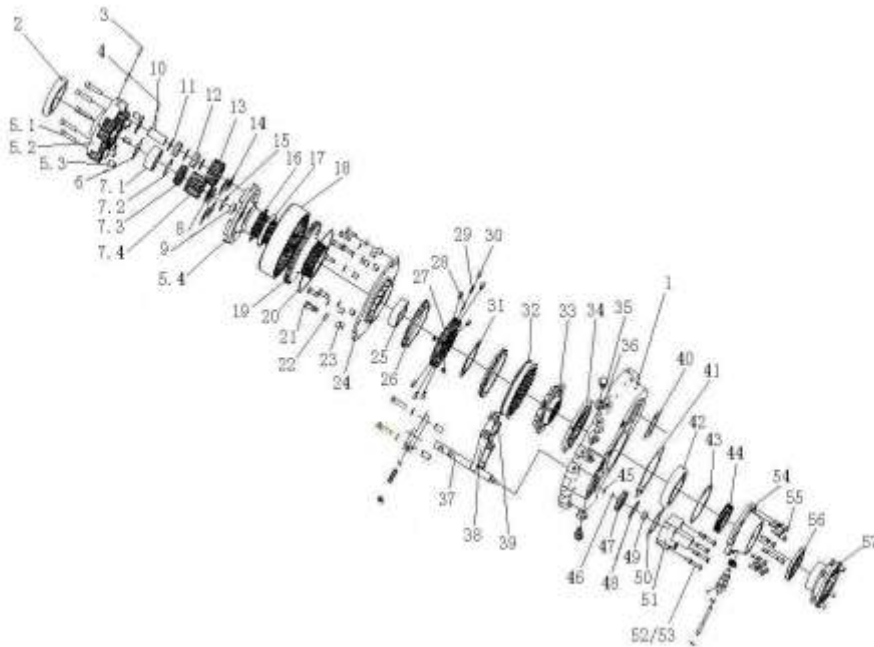

3.1.08 范围档副箱组件（取力器、电磁式传感器）/Sub Gearbox

序号	零部件图号	名称	Part Name	数量	备注
No.	Part No.			Qty	Remark
32	WG2210100059	范围档同步滑套	Sleeve	1	
33	WG2203100006	高档锥毂总成	Tapered plate assembly	1	
34	WG2203100007	导油环总成	Oil ring assembly	1	
35	WG2229100043	拨叉支撑销	Pin	2	
36	WG9003990024	波形弹性垫圈	Wave washer	2	

37	WG2214100002	范围档拨叉轴	Fork shaft	1	
38	WG2214100001	范围档拨叉	Fork	1	
39	AZ2229100022	拨叉摆块	Block	2	
40	WG2229100048	盖板衬垫	Gasket	1	
41	WG2229100041	输出轴后端盖纸垫	Gasket	1	
42	WG9003326218	滚动轴承6218 GB/T276	Roller bearing	1	
43	AZ2208100003	调整垫片组	Shim	1	
43,1	WG2229100035	调整垫片	Shim	1	
43,2	WG2229100036	调整垫片	Shim	1	
43,3	WG2229100037	调整垫片	Shim	1	
44	WG2210100020	传感器齿圈	Ring gear	1	
45	WG9003072503	O形圈35502500 GB3452.	O-ring	2	
46	WG9003071700	O形圈26500170 GB3452.	O-ring	1	
47	WG2229100050	范围档活塞	Piston	1	
48	WG9003076900	O形圈53006900 GB3452.	O-ring	1	

3.1.08 范围档副箱组件（取力器、电磁式传感器）/Sub Gearbox

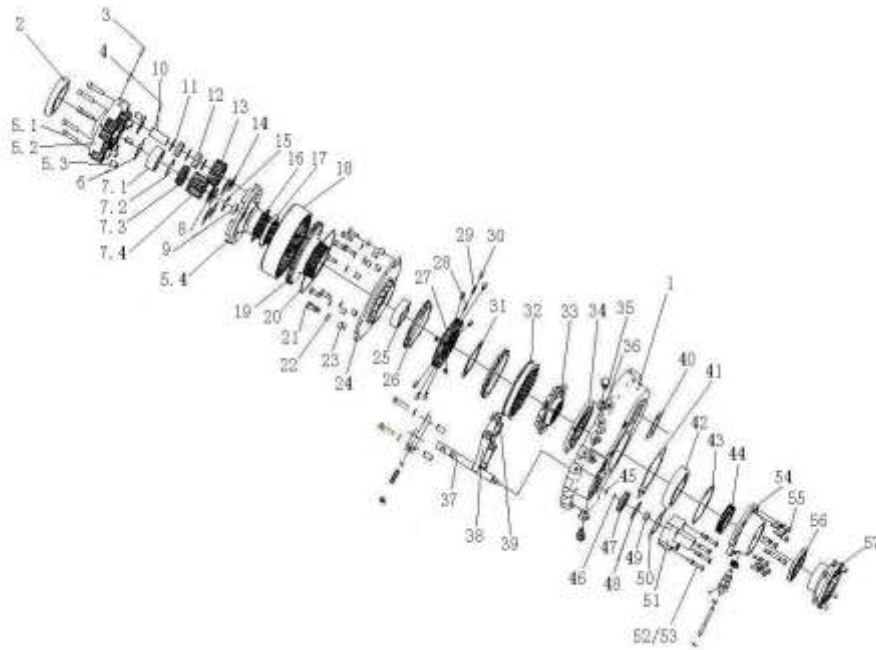

3.1.08 范围档副箱组件（取力器、电磁式传感器）/Sub Gearbox

序号	零部件图号	名称	Part Name	数量	备注
No.	Part No.			Qty	Remark
49	AZ9003870016	六角螺母M16×1.5	Nut	1	
50	WG2229100049	范围档气缸纸垫	Gasket	1	
51	WG2222100009	范围档气缸	Range cylinder	1	
52	Q150B1065	六角头螺栓	Bolt	4	
53	Q40310	弹簧垫圈	Spring washer	4	
54	WG2222100023	输出轴后端盖(双油封)	End cover	1	
55	Q150B1055	六角头螺栓	Bolt	7	
56	WG9003070105	骨架油封PS 105 130 14	Oil seal	1	

57	WG2210100018	输出法兰Φ180端面齿	Flange	1	
58	AZ9007970271	螺纹紧固胶LOCTITE271	Thread glue	1	
59	AZ9007990001	硅酮密封胶	Sealant	1	
60	Q40310	弹簧垫圈	Spring washer	8	
61	AZ9007970242	螺纹紧固胶LOCTITE242	Thread glue	1	
62	AZ9007990001	硅酮密封胶	Sealant	1	
63	WG2229100072	压板	Plate	1	
64	WG2229100073	螺栓	Bolt	1	
65	AZ9007970242	螺纹紧固胶LOCTITE242	Thread glue	1	
66	AZ9007990001	硅酮密封胶	Sealant	1	
67	WG2229100173	主副箱互锁板	Plate	1	
68	WG2229100052	锁板压板(小)	Plate	1	

3.1.08 范围挡副箱组件(取力器、电磁式传感器)/Sub Gearbox

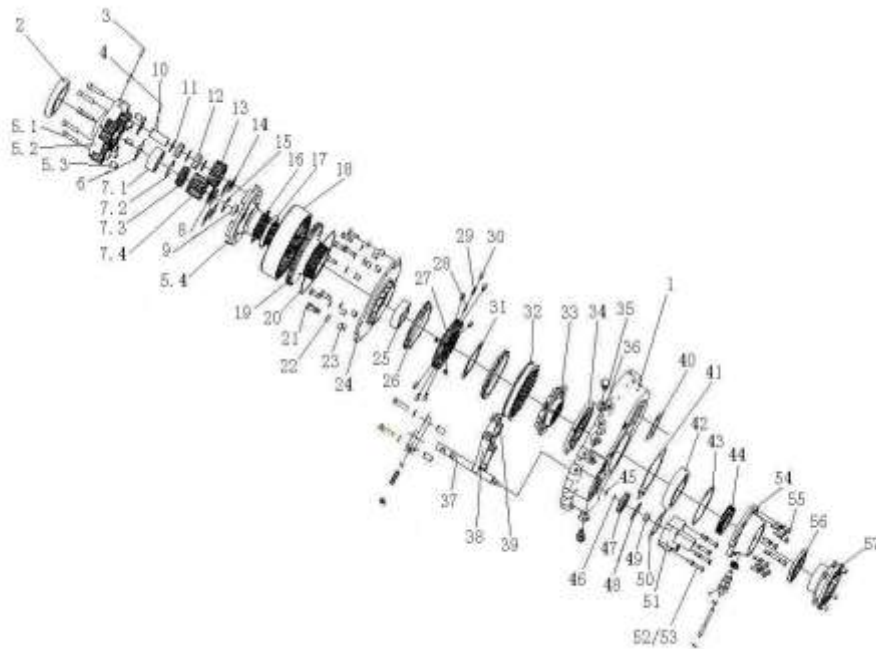

3.1.08 范围挡副箱组件(取力器、电磁式传感器)/Sub Gearbox

序号	零部件图号	名称	Part Name	数量	备注
No.	Part No.			Qty	Remark
69	WG2229100174	锁板压板(大)	Plate	1	
70	WG2229100054	压板垫块	Block	5	
71	WG2229100175	锁板垫板	Plate	1	
72	WG2229100056	锁板支销	Pin	1	
73	WG2229210019	范围档锁弹簧	Spring	1	
74	WG2203100012	弹簧定位销总成	localizer Pin assembly	1	
75	Q150B1025	六角头螺栓	Bolt	5	
76	Q150B1020	六角头螺栓	Bolt	1	
77	Q40310	弹簧垫圈	Spring washer	1	
78	AZ9007970271	螺纹紧固胶LOCTITE271	Thread glue	1	
79	WG2229100062	副箱纸垫	Paper gasket	1	

3.1.09 10挡小盖组件(双杆)/Small Cover

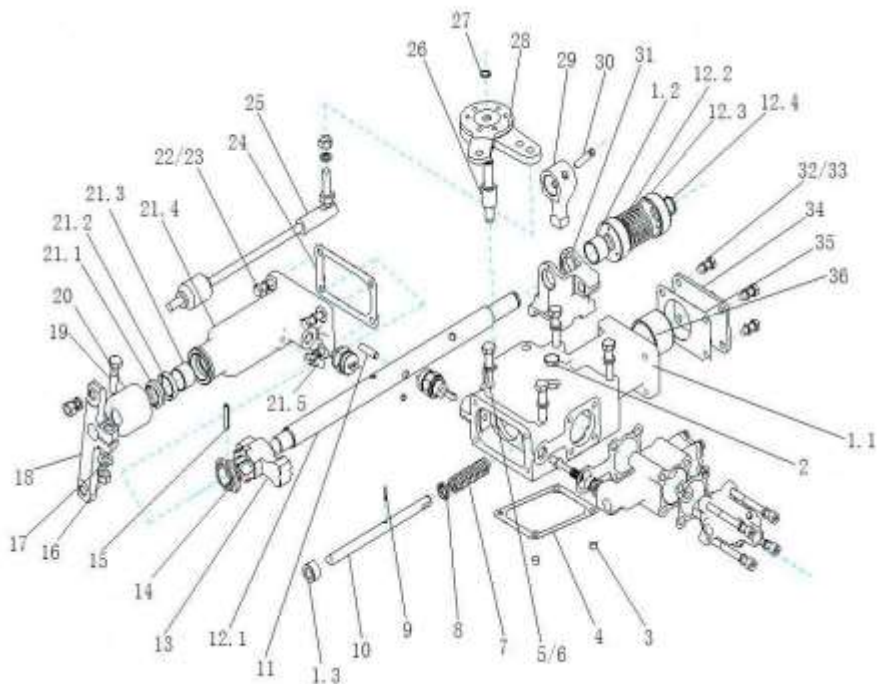

3.1.09 10挡小盖组件(双杆)/Small Cover

序号	零部件图号	名称	Part Name	数量	备注
No.	Part No.			Qty	Remark
1	AZ2203210030	小盖壳体总成	Housing assembly	1	
1,1	WG2222210038	小盖壳体(10挡, 双杆)	Housing assembly	1	
1,2	WG2229002520	复合衬套SF2 25×28×20	Bushing	1	
1,3	WG2229210001	衬套	Bushing	1	
1,4	AZ9007970001	LOCTITE粘结剂	LOCTITE	1	
2	Q72220	碗形塞片	Shim	1	
3	WG2229210036	定位导套	Sleeve	2	
4	WG2229210070	小盖纸垫	Gasket	1	
5	Q150B1085	六角头螺栓	Bolt	4	
6	Q40310	弹簧垫圈	Spring washer	4	
7	WG2229210333	自锁弹簧	Spring	1	
8	WG2229210011	弹簧挡片	Spacer	1	
9	AZ9003343178	滚针P3×17.8 GB309	Needle	1	
10	WG2212210005	自锁销轴	Pin	1	
11	WG2229210012	驱动销	Pin	1	
12	AZ2203210038	换挡轴总成	Shaft assembly	1	
12,1	WG2212210007	换挡轴(双杆)	Shaft	1	

12.2	WG2229210003	定中弹簧(高档侧)	Spring	1	
12.3	AZ2229210007	定中座环	Ring	2	
12.4	Q43120	轴用弹性挡圈	Circlip	1	

3.1.09 10挡小盖组件(双杆)/Small Cover

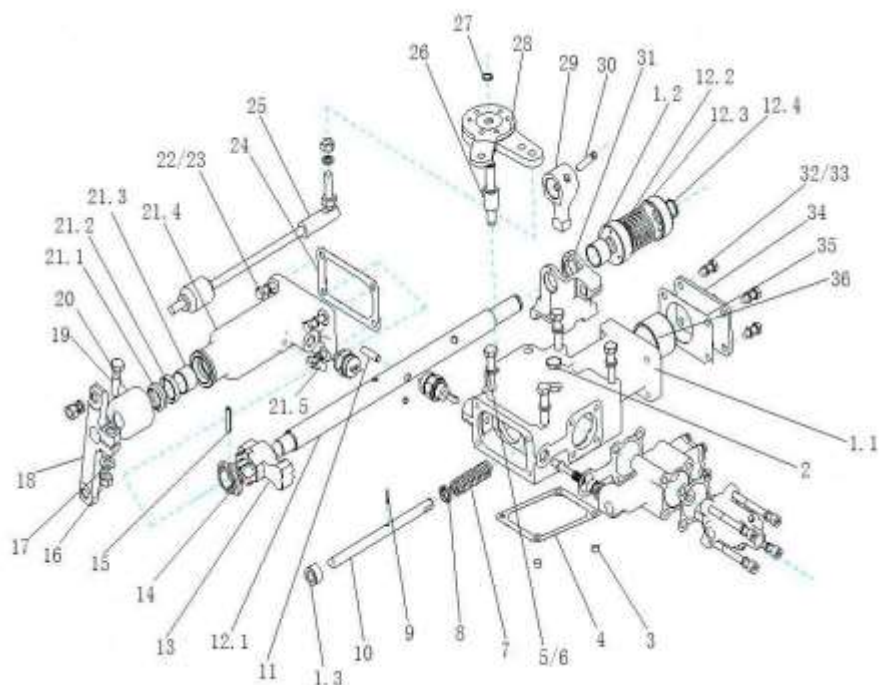

3.1.09 10挡小盖组件(双杆)/Small Cover

序号 No.	零部件图号 Part No.	名称	Part Name	数量 Qty	备注 Remark
13	WG2229210008	扇形自锁块	Block	1	
14	WG2229210014	传感器驱动环	Ring	1	
15	Q5280632	弹性圆柱销	Pin	1	
16	Q340B10T13F2	I型六角螺母	Nut	1	
17	Q41810	波形弹性垫圈	Wave washer	1	
18	WG2214210004	摇臂	Rocker arm	1	
19	Q150B1040TF2	六角头螺栓	Bolt	1	
20	WG2229210026	防尘罩	Dust shield	1	
21	AZ2203210008	小盖端盖总成(双杆)	Cover assembly	1	
21.1	WG9003072502	端盖外油封	Oil seal	1	
21.2	WG9003072501	端盖内油封	Oil seal	1	
21.3	WG2229002520	复合衬套SF2 25×28×20	Bushing	1	
21.4	WG2222210034	小盖端盖(双杆摇臂侧)	Cover	1	
21.5	Q901	常开式通气塞	Breather	1	
22	Q150B0825	六角头螺栓	Bolt	4	
23	Q40308	弹簧垫圈	Spring washer	4	
24	WG2229210017	端盖衬垫	Gasket	1	
25	WG2229210041	支撑杆总成	Rod assembly	1	
26	WG2229270003	选档支撑轴	Shaft	1	
27	Q43112	轴用弹性挡圈	Circlip	1	

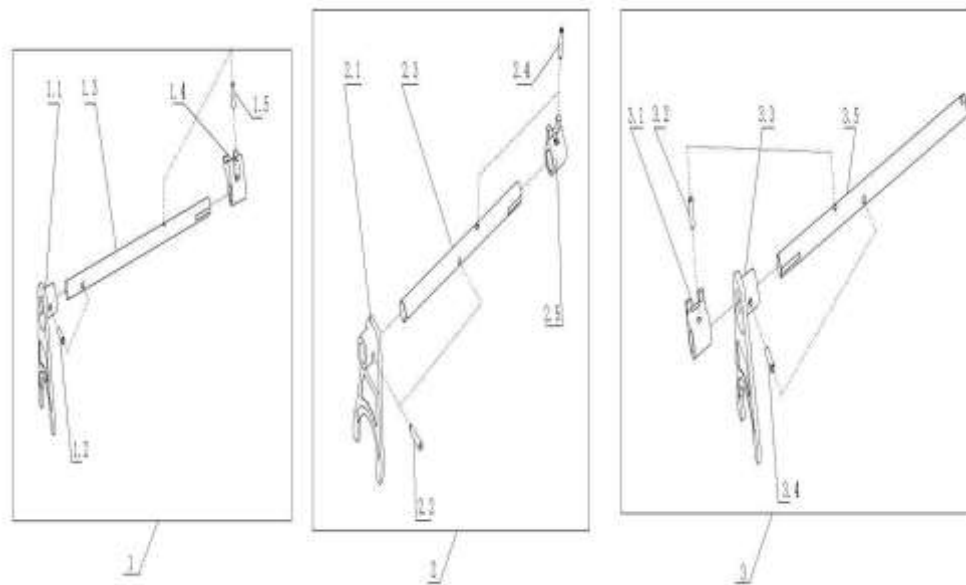

3.1.10 拨叉轴组件/Fork Shaft

序号 No.	零部件图号 Part No.	名称	Part Name	数量 Qty	备注 Remark
1	AZ2203220101	倒爬挡拨叉轴总成	Reverse gear fork shaft ass.	1	
1,1	WG2214220001	拨叉	Fork	1	
1,2	WG2229220002	销	Pin	1	
1,3	WG2212220201	倒爬挡拨叉轴	Reverse gear fork shaft	1	
1,4	WG2214220002	倒挡拨块	Block	1	
1,5	WG2229220001	销	Pin	1	
2	AZ2203220010	一、二挡拨叉轴总成	1st&2nd gear fork shaft ass	1	
2,1	WG2214220001	拨叉	Fork	1	
2,2	WG2229220002	销	Pin	1	
2,3	WG2212220102	一、二挡拨叉轴	1st&2nd gear fork shaft	1	
2,4	WG2229220001	销	Pin	1	
2,5	WG2214220004	前进挡拨块	Block	1	
3	AZ2203220103	三、四挡拨叉轴总成	3rd&4th gear fork shaft ass	1	
3,1	WG2214220003	前进挡拨块	Block	1	
3,2	WG2229220001	销	Pin	1	
3,3	WG2214220001	拨叉	Fork	1	
3,4	WG2229220002	销	Pin	1	
3,5	WG2212220103	三、四挡拨叉轴	3rd&4th gear fork shaft	1	

3.1.11 油泵及管路组件(取力器)/Oil Pump And Pipe



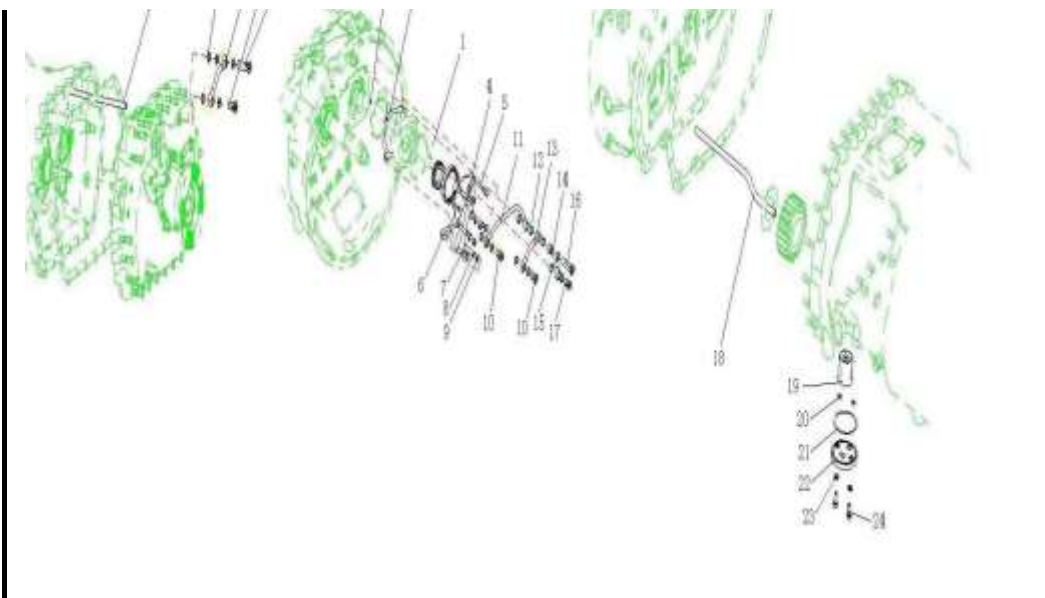

3.1.11 油泵及管路组件(取力器)/Oil Pump And Pipe

序号	零部件图号	名称	Part Name	数量	备注
No.	Part No.			Qty	Remark
1	WG2203240005	油泵总成	Oil pump	1	
2	WG9003338000	钢球8.000 G200b GB308	Ball	1	
3	WG2229000005	副轴端盖纸垫	Gasket	1	
4	Q40110	平垫圈	Washer	2	
5	Q150B1070	六角头螺栓	Bolt	4	
6	WG2229240030	进油管纸垫	Gasket	1	
7	Q150B1040	六角头螺栓	Bolt	1	
8	Q40310	弹簧垫圈	Spring washer	4	
9	Q150B1090	六角头螺栓	Bolt	1	
10	190003962627	空心螺栓	Hollow bolt	2	
11	WG2203240013	箱体进油管总成	Tube assembly	1	
12	WG9004130016	组合密封垫圈	Gasket assembly	8	
13	WG2203240012	输入轴进油管总成	Tube assembly	1	
14	WG2203240011	出油管总成	Tube assembly	1	
15	WG9004130016	组合密封垫圈	Gasket assembly	2	
16	WG9003961670	空心螺栓	Hollow bolt	1	
17	190003962627	空心螺栓	Hollow bolt	1	
18	WG2229240107	箱内管1	Tube	1	
19	WG2203240007	滤网总成	Net assembly	1	
20	WG9003070085	O形圈26500850 GB3452.	O-ring	2	

3.1.11 油泵及管路组件(取力器)/Oil Pump And Pipe



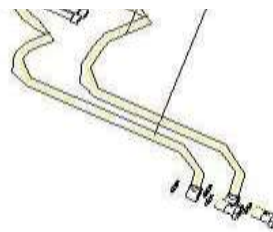

3.1.12 气动管路阀组件/Air Pipe And Valve

序号 No.	零部件图号 Part No.	名称	Part Name	数量 Qty	备注 Remark
1	WG2229250023	气控阀纸垫	Gasket	1	
2	WG2229250015	锁止销	Pin	1	
3	WG2229250004	弹簧	Spring	1	
4	WG2229250017	衬套	Bushing	1	
5	WG9003071700	O形圈26500170 GB3452.	O-ring	1	
6	WG2229250006	直通(NPT 1/8-4X2)	Nozzle	1	
7	WG2203250010	气控锁止阀总成	Air control valve assembly	1	
8	WG2229250024	双H阀衬垫	Gasket	1	
9	WG2203250003	双H阀总成	Valve	1	
10	Q72314	密封垫圈	Gasket	8	
11	190003962621	空心螺栓	Hollow bolt	4	
12	Q218B0880	内六角圆柱头螺钉	Screw	4	
13	Q40308	弹簧垫圈	Spring washer	4	
14	WG2203250019	范围挡成型软管总成(高)	Hose	1	
15	WG2203250018	范围挡成型软管总成(低)	Hose	1	

3.1.13 离合器操纵组件/Clutch Control System

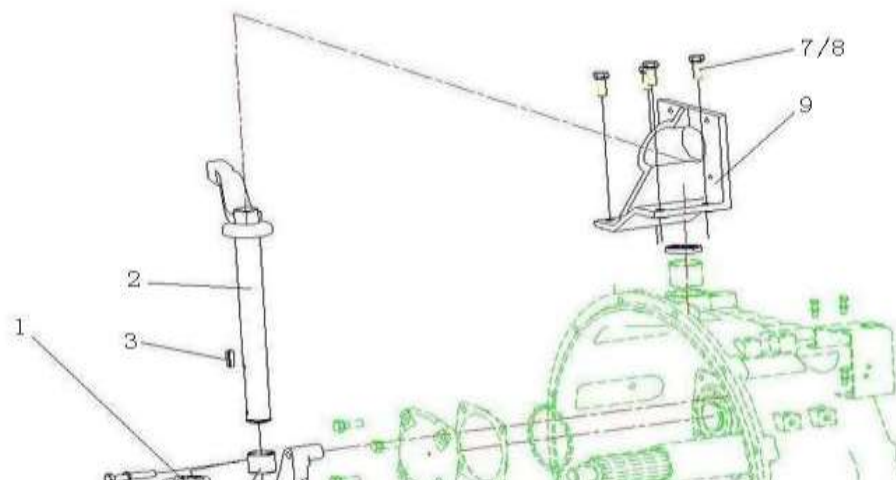

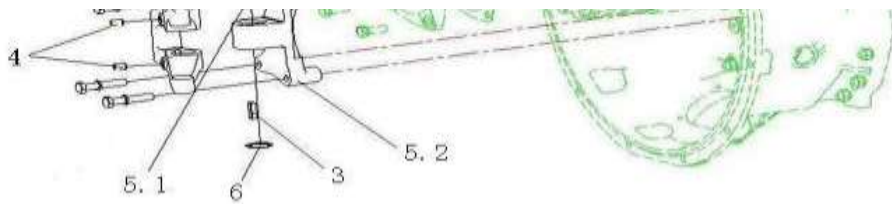

3.1.13 离合器操纵组件/Clutch Control System

序号 No.	零部件图号 Part No.	名称	Part Name	数量 Qty	备注 Remark
1	WG2214260001	离合器分离拨叉	Fork	1	
2	WG2203260008	拨叉轴总成	Shaft assembly	1	
3	Q5510825	普通平键	Key	2	
4	Q2881016F9	内六角锥端紧定螺钉	Screw	2	
5	AZ2203260001	拨叉轴支架总成	Bracket assembly	1	
5.1	WG2229003030	复合衬套	Bushing	1	
5.2	WG2229260001	拨叉轴支架	Bracket	1	
6	Q43130	轴用弹性挡圈	Circlip	1	
7	Q150B1030	六角头螺栓	Bolt	4	
8	Q40310	弹簧垫圈	Spring washer	4	
9	WG2229260016	助力缸支架	Bracket	1	
10	Q40310	弹簧垫圈	Spring washer	3	
11	AZ9007970242	螺纹紧固胶	Thread glue	1	
12	AZ2229260014	盖板	Cover	1	
13	Q150B0615	六角头螺栓	Bolt	4	
14	Q40306	弹簧垫圈	Spring washer	4	
15	WG9003801062	六角头螺栓Q150B1062	Bolt	3	

3.1.14 变速器操纵附件/Transmission Control Accessory

